

# OPERATING INSTRUCTIONS

## SCAN-LINE 40 SCAN-LINE 50



[www.heta.dk](http://www.heta.dk)

Congratulations on your new stove. We are sure that you will be happy with your investment, especially if you follow the advice and instructions we have put together in these operating instructions.

The Scan-Line 40 and 50 have been approved according to the EN 13240 / NS 3058.

Approval means that consumers can be sure, that the stove meets a range

of specifications and requirements intended to ensure that the materials used are of good quality, that the stove does not adversely affect the environment, and that it is economical to use.

With your new stove you should have received the following:

- a. Operating instructions
- b. A stove glove

## INSTALLATION INSTRUCTIONS

### Safety clearances

Stoves must always be installed in line with national and, if applicable, local regulations. It is important to abide by local regulations regarding setting up chimneys and connection to same. Therefore, always consult your local chimney sweep before installation, as you are personally responsible for ensuring that the applicable regulations have been met.

### Distance regulations

A difference applies to installation next to flammable and non-flammable walls.

If the wall is made of non-flammable material the stove can, in principle, be placed flush against it. However, we recommend leaving a gap of at least 5 cm to facilitate cleaning behind the stove.

**The minimum distances to flammable material are stated on the boiler plate and are listed in the table on page 6.**

### Warning



**A stove gets hot. (In excess of 90 degrees) Take care to ensure that children and elderly or infirm people cannot come into contact with it. Combustible materials should not be stored in the compartment below the ashpan.**

### IMPORTANT

1. Make sure there is adequate provision to sweep the chimney.
2. Make sure there is adequate ventilation to the room.
3. Please note that any extraction fans operating in the same room as the wood-burning stove can reduce the chimney draft – which may have an adverse effect on stove combustion properties. In addition, this may cause smoke to be emitted from the stove when the firing door is opened.
4. It must not be possible to cover any air vents.

### The floor

It is essential to ensure that the floor surface can actually bear the weight of the stove and a top-mounted steel chimney, if applicable. The stove must stand on a nonflammable surface such as a steel floor plate or a brick or tile floor. The size of the nonflammable surface used to cover the floor area must match national and local regulations.

### The chimney connection

The chimney opening must follow national and local regulations. However, the area of the opening should never be less than 175 cm<sup>2</sup>, which corresponds to a diameter of 150 mm. If

a damper is fitted in the flue gas pipe, there must always be at least 20 cm<sup>2</sup> of free passage, even when the damper is in its "closed" position. If local regulations permit, two contained fireplaces can be connected to the same chimney. However, you must abide by local regulations regarding the distance between the two connections.

**Wood-burning stoves must never be connected to chimneys that are also linked to a gasfired heater.** An efficient stove makes high demand on chimney properties – so always have your local chimney sweep evaluate your chimney.

### **Connection to a brick chimney**

Brick a thimble into the chimney and seat the flue gas pipe in this. The thimble and flue gas pipe must not penetrate the chimney opening itself, but must be flush with the inside of the chimney duct. Joins between brickwork, the thimble and flue gas pipe must be sealed with fireproof material and/or beading.

### **Connection to a steel chimney**

When fitting a connection from a top-output stove directly to a steel chimney, we recommend fitting the chimney tube inside the flue gas spigot so that any soot and condensation drops into the stove itself rather than collecting on the exterior surface of the stove. For connections to chimneys that are run through ceilings, all national and local regulations regarding distance to flammable material must be followed. It is important that the chimney is fitted with roof support so that the top panel of the stove is not required to bear the entire weight of the chimney (excessive weight may damage the stove).

### **Draft conditions**

Poor draft may result in smoke being emitted from the stove when the door is opened. The minimum chimney draft to ensure satisfactory combu-

stion in stoves of this kind is 11 PA. However, there will still be a risk of smoke emission if the firing door is opened during powerful firing. The flue gas temperature at nominal output is 246°C when expelled to an exterior temperature of 20°C. The flue gas mass flow is 4,7 g/sec. The chimney draft is generated by the difference between the high temperature of the chimney and the low temperature of the fresh air. The length and insulation of the chimney, wind and weather conditions also have an effect on the ability of the chimney to generate appropriate under-pressure.

If the stove has not been used in a while, check that the chimney and stove are not blocked with soot, bird nests, etc., before using it.

### **Reduced draft can occur when:**

- The difference in temperature is too small - due to insufficient chimney insulation, for example.
- The outdoor temperature is too high in summer, for example.
- No wind is blowing.
- The chimney is too low and sheltered.
- The chimney contains false air.
- The chimney and flue gas pipe are blocked.
- The house is too airtight (i.e. when there is an insufficient supply of fresh air).
- Poor smoke extraction (poor draft conditions) due to a cold chimney or bad weather conditions can be compensated for by increasing the airflow into the stove.

### **Good draft occurs when:**

- The difference in temperature between the chimney and outdoor air is high.
- The weather is fine.
- The wind is blowing strongly.
- The chimney is of the correct height: at least 4.00 m above the stove and free of the roof ridge.

# INSTRUCTIONS FOR USE

## First firing

The stove paint is fully cured from the factory, but a minor unpleasant odour could still arise.

## Fuel

Your new stove is EN approved for firing with wood fuel. You must therefore only burn clean, dry wood in your stove. Never use your stove to burn driftwood, as this may contain a lot of salt which can damage both the stove and the chimney. Similarly, you must not fire your stove with refuse, painted wood, pressure-impregnated wood or chipboard, as these materials can emit poisonous fumes and smoke. Correct firing using well seasoned wood provides optimal heat output and maximum economy. At the same time, correct firing prevents environmental damage in the form of smoke and emissions and also reduces the risk of chimney fires. If the wood is wet and inadequately seasoned, a large proportion of the energy in the fuel will be used to vaporise the water, and this will all disappear up the chimney. Thus it is important to use dry, well seasoned wood, i.e. wood with a moisture content of no more than 18%. This is achieved by storing the wood for 1–2 years before use. Pieces of firewood with a diameter of more than 10 cm should be split before storing. The pieces of firewood should be of an appropriate length (approx. 25–30 cm) so that they can lie flat on the bed of embers. If you store your wood outdoors, it is best to cover it.

## Examples of fuel values of different woods

Fuel type / number of cubic metres per 1,000 litres of oil

| Oak | Beech | Ash | Birch | Elm | Common spruce |
|-----|-------|-----|-------|-----|---------------|
| 7.0 | 7.0   | 7.2 | 8.0   | 8.9 | 10.4          |

## Chimney fires

In the event of a chimney fire – which often results from incorrect operation or protracted firing with moist wood – close the door and shut off the secondary/start-up air supply to smother the fire. Call the fire department.

## Lighting and combustion

To open the flow of secondary air, use the operating handle at the front of the stove. The secondary airflow is completely open when the handle is to the left side position, fig. 1. Shut off the secondary airflow gradually by moving the handle to the right. The supply is completely shut off when the handle is to the right side position, fig. 2.

## Lighting

To ignite the fuel, use fire lighters, small paraffin ignition bags or small pieces of wood placed on the bottom grate. Place larger pieces of wood on

Fig. 1

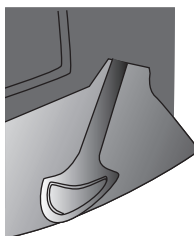

Open

Fig. 2

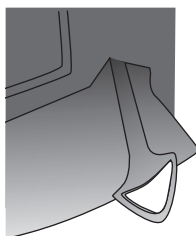

Closed

top of this kindling material, at right angles to the firing, doors. Completely open the secondary air supply and leave the firing door ajar – i.e. approx. 1 cm open. Once the fire has taken a good hold of the fuel and the chimney has heated up (after about 10 min) close the firing door. We recommend that you burn the entire first firing with the secondary air supply fully open to make sure that the chimney is thoroughly heated.

### Refiring

You should normally refire the stove while there is still a good layer of embers. Distribute the embers across the bottom grate, place pieces of fuel (max. 2 kg) on the embers in a single layer perpendicular to the firing opening. Close the firing door and fully open the start-up mechanism. The wood will then ignite very quickly – i.e. in 30 seconds or 1 minute. When the wood is burning with a steady flame, close the start-up mechanism. Then adjust the secondary airflow to the level required. For nominal operation (6,1 kW), the secondary air supply should be 38% open. When firing, take care not to place the pieces of fuel too close-ly together, as this will result in poor combustion and insufficient exploitation of the fuel.

### Reduced burning

The stove is well-suited to intermittent use. If you wish to operate the stove with reduced out-put, simply insert smaller volumes of wood at each firing, and apply a lower airflow. However, remember that the secondary combustion air supply must never be shut off completely during firing. It is important to keep a good bed of embers. Gentle heat is released when the fire settles - i.e. when the wood no longer generates flames and has been converted to glowing embers.

### Optimal firing

To achieve optimal firing and the highest possible effect, it is important to make sure that the air supply is used correctly. As a general rule, the secondary air is to be used to control the fire to ignite the flue gases. This produces a high effect and keeps the glass panel completely clear of soot as the secondary air “washes” down over it. Please note that the stove will, naturally, produce soot if both the start-up mechanism and secondary air intakes are closed completely. This will prevent oxygen from being drawn into the stove, and the viewing window and other parts will become covered with soot. If this situation is combined with firing with wet wood, the build-up of soot can become so thick and sticky that the sealing rope can, for example, become detached when the door is opened the next day.

### Risk of explosion



**After you add new fuel, it is very important that you do not leave the stove unattended until the wood is burning constantly. This will normally occur within 30 to 60 seconds.**

A risk of explosion can possibly arise if too much wood is placed in the stove. This may result in the production of large volumes of gas, and this gas can explode if the intake of primary and secondary air is insufficient. It is an advantage always to leave some ash lying in the bottom of the combustion chamber.

**Take care when emptying the ash pan, as cinders can continue to burn in the ash for long periods of time.**

## Stove data table in accordance with EN 13240 testing.

| Stove type<br>Scan-Line series | Nominal fluegas temperature c° | Smoke stub<br>mm | Fuel volume<br>kg | Draught min<br>mbar | Nominal output tested<br>kW | Energy efficiency<br>kW | Distance to flammable materials in mm<br>behind the stove | at the sides | Distance to furnitures from the stove in mm | Stove weight<br>kg |
|--------------------------------|--------------------------------|------------------|-------------------|---------------------|-----------------------------|-------------------------|---|--------------|---|--------------------|
| 40                             | 246                            | ø150             | 1.2               | 0.11                | 6,1                         | 83                      | 150   | 350          | 1000  | 468                |
| 50                             | 246                            | ø150             | 1.2               | 0.11                | 6,1                         | 83                      | 150   | 350          | 1000  | 582                |

The nominal output is the output to which the stove has been tested. The test was carried out with the secondary air 38% open.

## OPERATIONAL PROBLEMS

The chimney must be swept at least once a year, we recommend the use of a NACS (national association of chimney sweeps) registered chimney sweep. In the event of smoke or malodorous fumes being produced, you must first check to see whether the chimney is blocked. The chimney must, of course, always provide the minimum draught necessary to ensure that it is possible to regulate the fire. Please note, however, that chimney draft is dependent on the weather conditions. In high winds, the draft can become so powerful that it may be necessary to fit a damper in the

flue gas pipe to regulate the draft. When cleaning the chimney, soot and other deposits may come to fall on the smoke plate. In cases where the wood burns too quickly, this may be due to excessive chimney draught. You should also check to make sure that the door seal and ashpan seal is intact and correctly fitting. If the stove is generating too little heat, this may be because you are firing with wet wood. In this case, much of the heating energy is used to dry the wood, resulting in poor heating economics and an increased risk of soot deposits in the chimney.

## MAINTENANCE

The surface of the stove has been treated with heat-resistant paint. The stove should be cleaned with a damp cloth. Any damage to the surface in the form of chips or scratches can be repaired using touch-up paint, which is available in spray cans.

### Cleaning the glass

Incorrect firing, for example using wet wood, can result in the viewing window becoming covered in soot. This soot can be easily and effectively removed by using proprietary stove glass cleaner.

## Cleaning after sweeping the chimney and replacing the stones. Fig 3-6

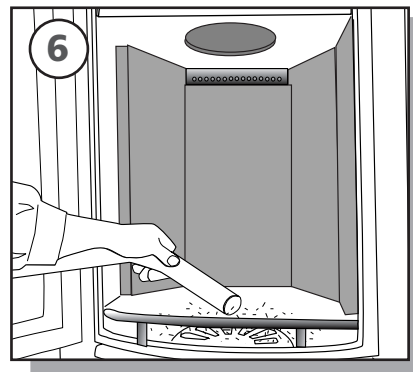
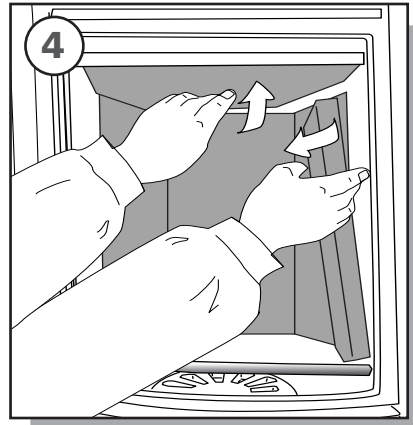
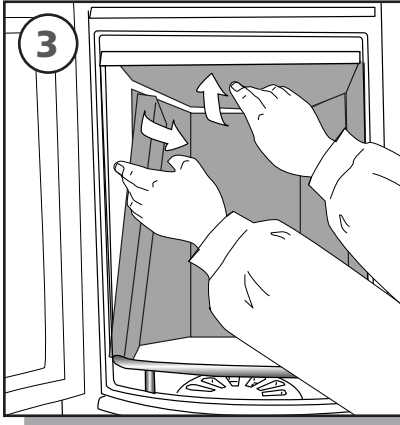

### GUARANTEE

The model Scan-Line 500 stoves are subjected to stringent quality control procedures both throughout the production process and immediately before delivery to the dealer. Therefore, the stoves are guaranteed against defects in manufacturing FOR FIVE YEARS.

This guarantee does not cover: Wearing parts/fragile parts such as:

- The fire-proof bricks in the combustion chamber.
- The smoke baffle
- The glass
- The sealing rope
- The grate frame

Damage resulting from incorrect use  
Transport costs in connection with repairs carried out under guarantee  
Installation/disassembly in connection with repairs carried out under guarantee. Should you have cause to make a complaint, please quote our invoice no.

### Warning



Any unauthorised modification of the stove and any use of non-original spares will void the guarantee.

# CONNECTION OF EXTERNAL AIR FLOW (FRESH AIR)

There is 140 cm from the outside of rear soapstone to the center of the hole for the external air flow connection through the floor. The pipe must fit a flexible  $\phi 100$  mm hose.

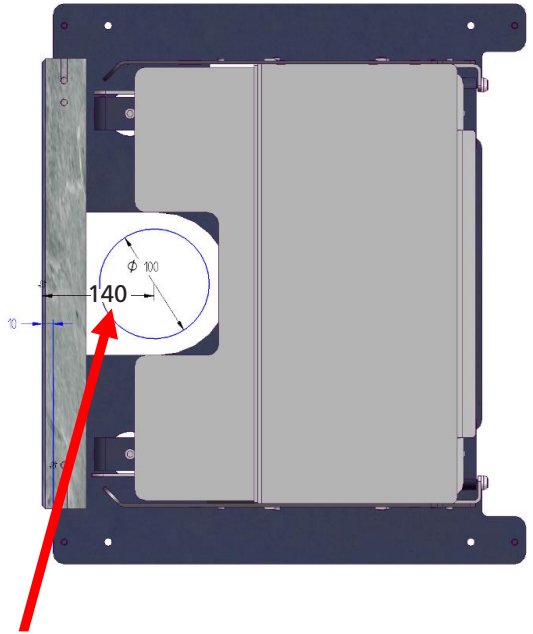

The external air can be supplied to the stove both from below by removing the pre cut bottom or through the air intake hole in the bottom stone.

*It is recommended to use an  $\phi 100$  mm alu flex hose that can withstand temperatures up to 200°.*

*The flexible hose is not included, but can be purchased separately.*

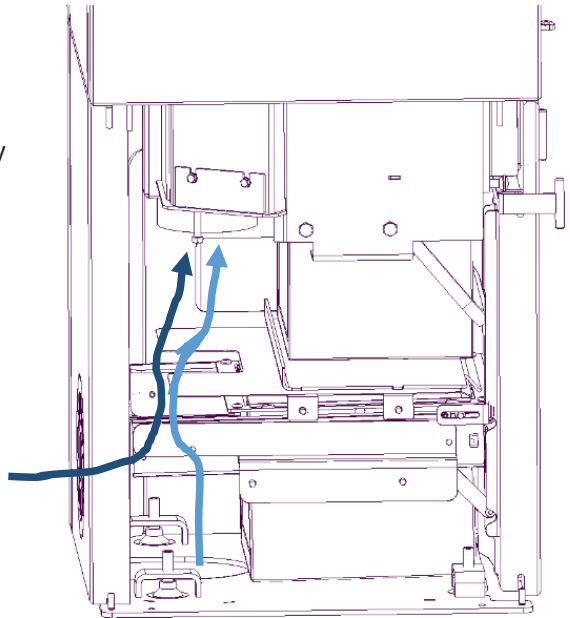



# INSTALLATION INSTRUCTIONS

## Scan-Line 40 and 50

Please read carefully before installing the stove. **NB!** Before assembling the soapstones, ensure that the underlay/floor is level and that the distance from the floor to the top plate is 1030 mm. The stove must be in level. To adjust, turn the adjusting screws on the base up/down.

We recommend installation of the soapstones is carried out by two people.

A standard set of brackets and pins are provided for installation of the soapstones. Refer to the overview on page 10 and 20 to see how many brackets/pins are required.

If required, lubricate the pin holes with a small amount of silicon. Can also be applied between the stones.

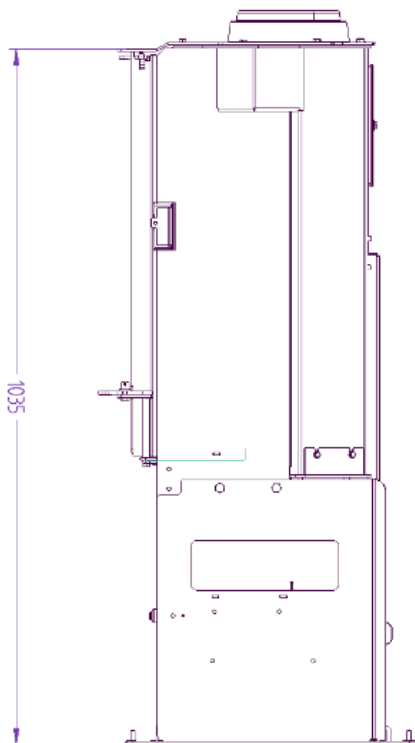
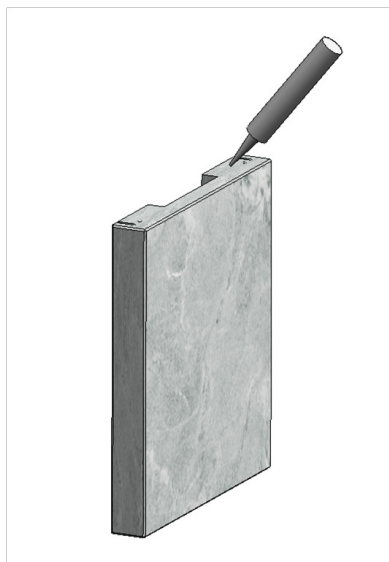

Fig. 1



# SCAN-LINE 40

16 x standard  
brackets



12 x standard  
pins

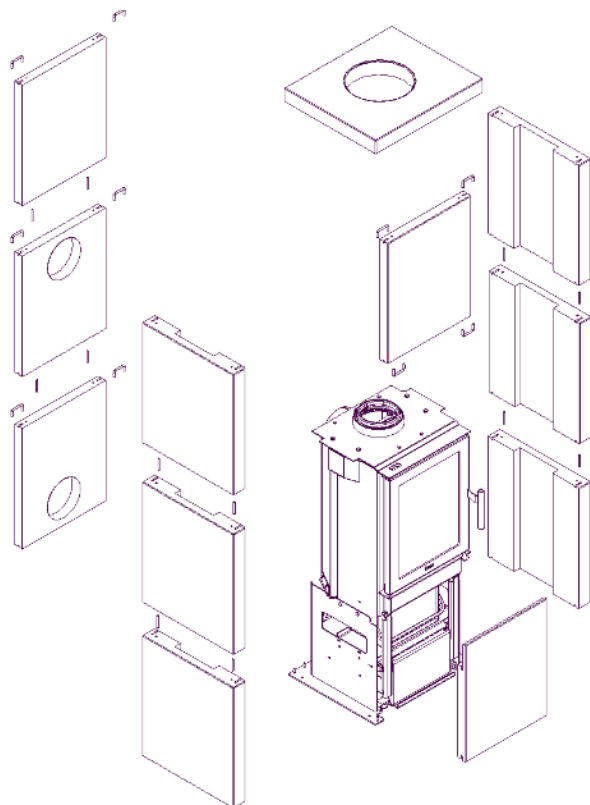
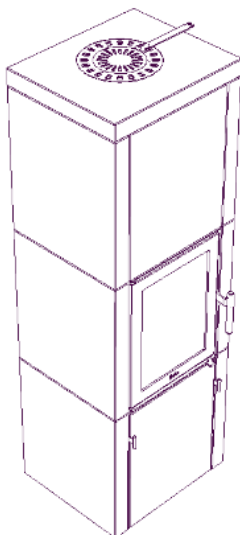

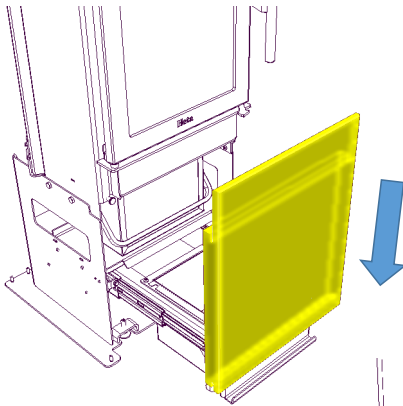

Place the stone into the groove on the door so that it is equidistant to both sides. Important! The stone must be manually held in place until the handle is fitted.

Fig. 2

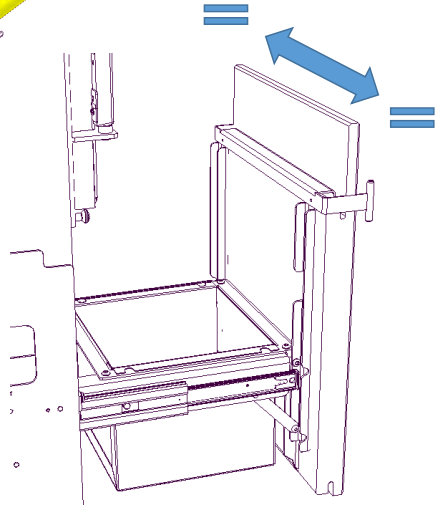

The handle is fitted by placing it into the groove in the stone and the ash pan frame. Adjust the handle so that it is placed in the middle of the ash pan frame.

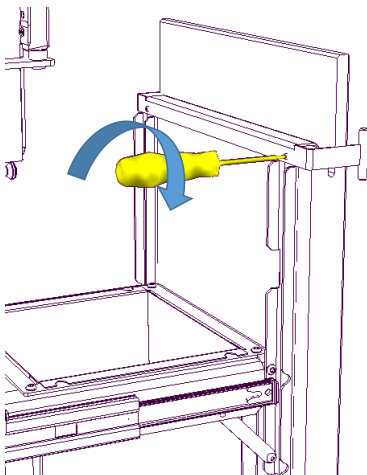

Tighten the handle with the supplied two M5x6 screws.

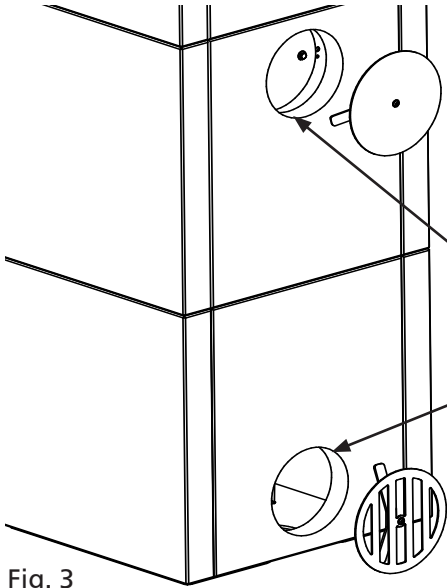

**NB:** Behind the stove, the stone with hole for convection, must be placed at the bottom. The next stone with hole is put on top if there is smoke outlet behind. Fig. 3

The closed cover should be placed here unless the stove should be mounted with back outlet

The open cover should be placed here.

Fig. 3

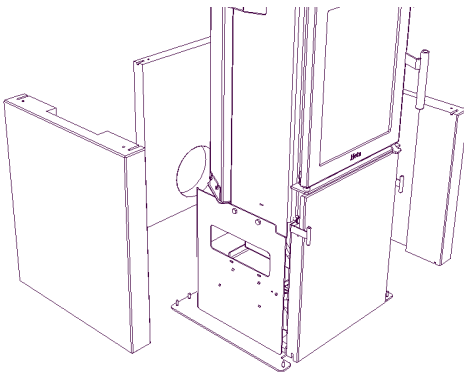

Continue with sidestones as shown i fig. 4. and place Brackets under. Then place the backstone with hole for convection and finish the first round with af sidestone.

Fig. 4

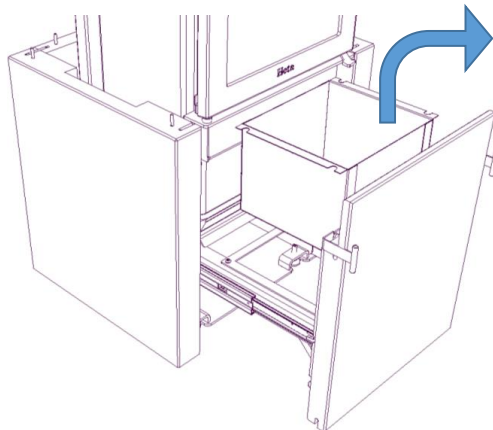
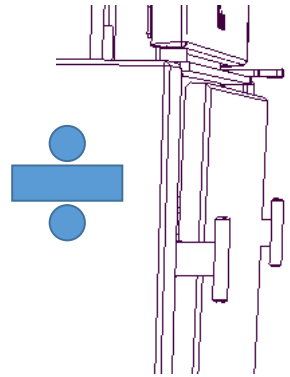
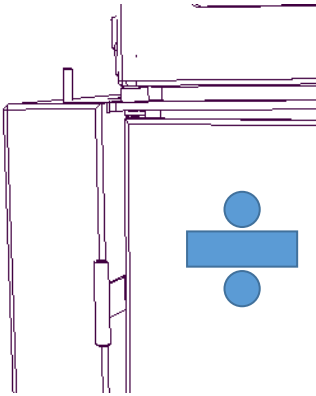
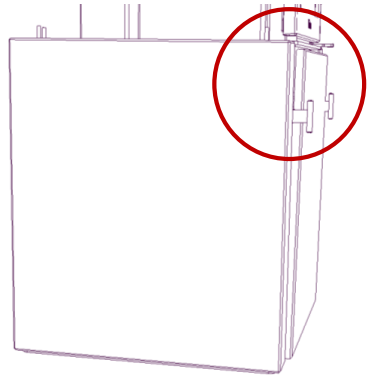
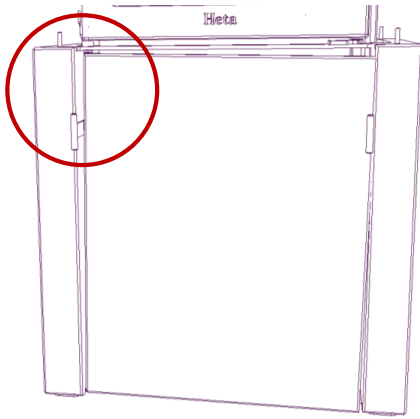

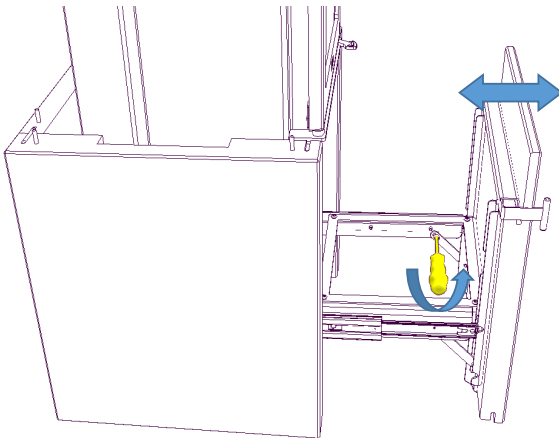
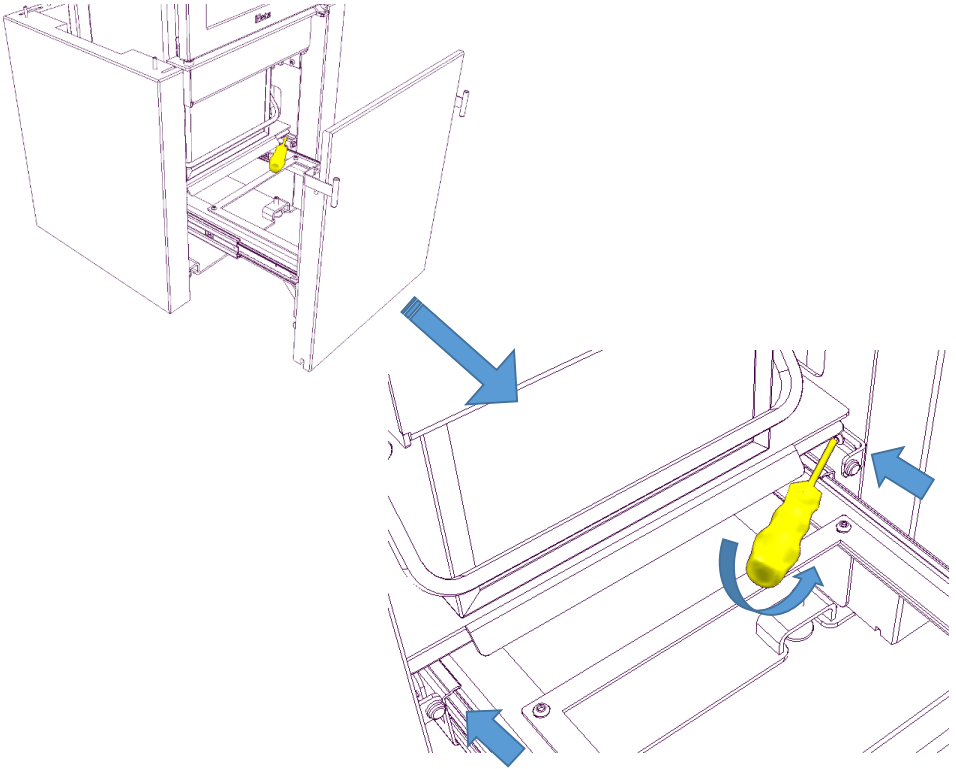

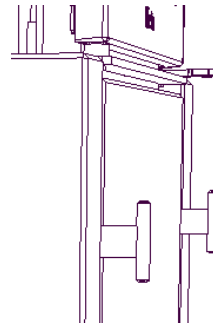
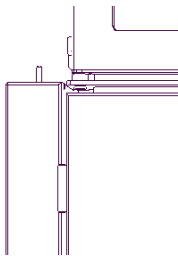
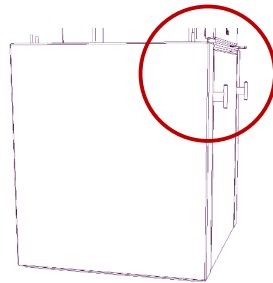
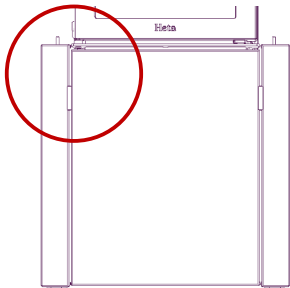
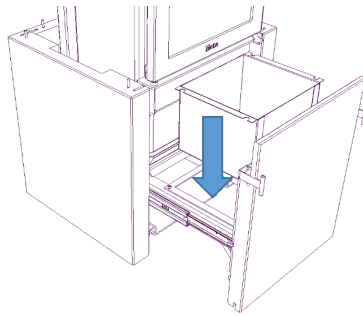
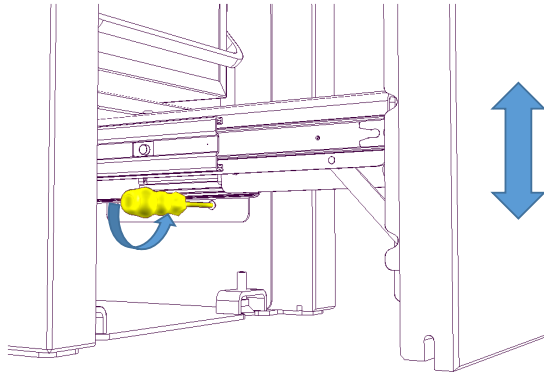
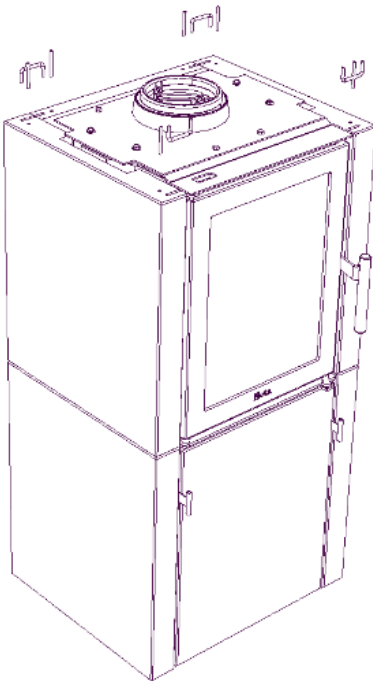
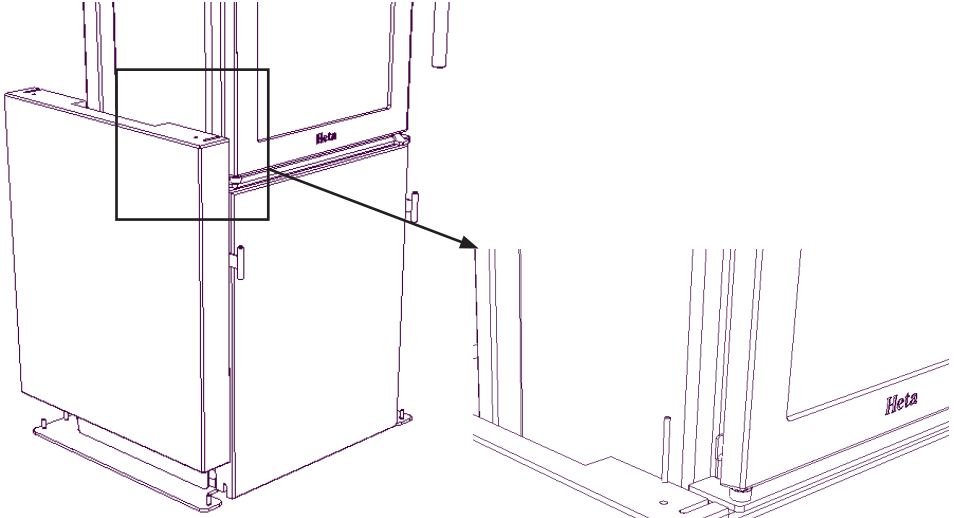

Fig. 5

Put brackets and pins in as shown. fig. 5.



Continuing with the next row. Start with sidestone, backstone and then sidestone again. Place brackets and pins. fig. 6



# THERMASTONES

Optional thermastones are also available. Three thermastones can be installed in this stove.

The thermastones must be added after the soapstones have been placed and the stove/firebox has been adjusted.

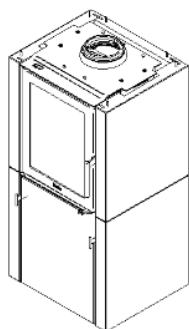

Step 1

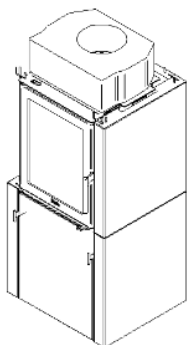

Step 2

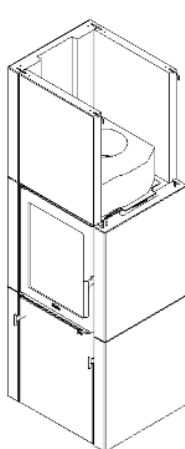

Step 3

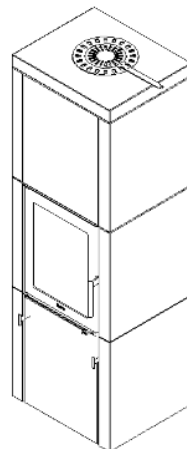

Step 4

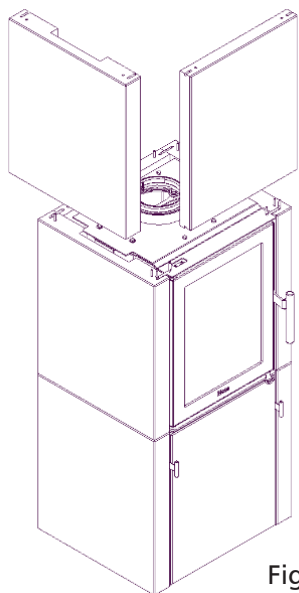

Fig. 7

Continue with the 3. row. Start with the front stone with the two brackets beneath (resting on the metal frame) and then a side stone, which should be placed on the pins/brackets. fig. 7

Continue with the back stone and then the last side stone. Place brackets on top. No pins are necessary Fig. 8

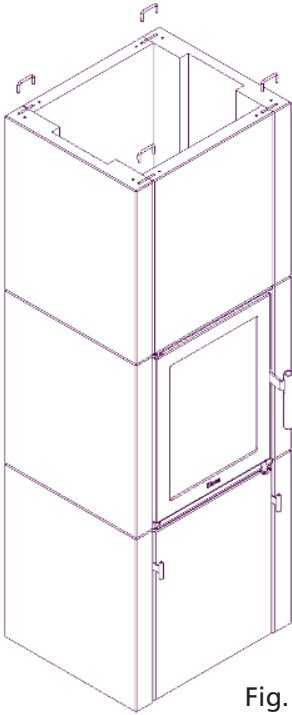

Fig. 8

Finish with the topstone - place in it loose on top. If the stove has a top flue, break of the inner ring. Fig. 9

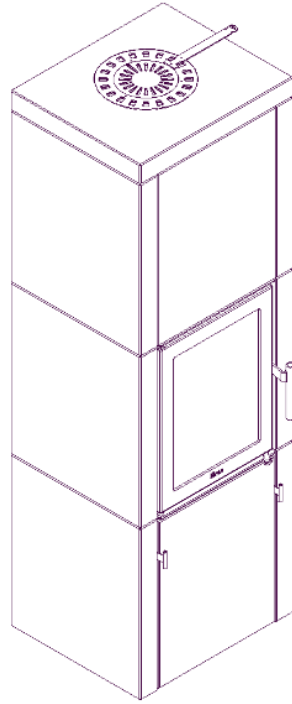
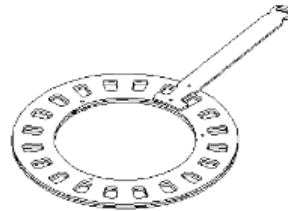
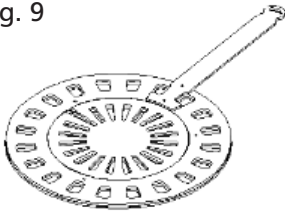
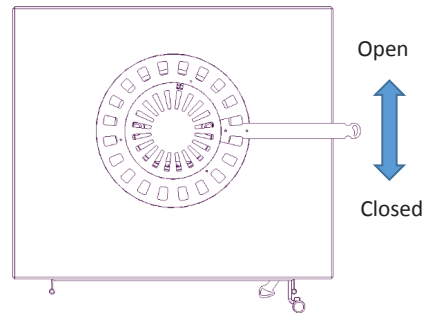
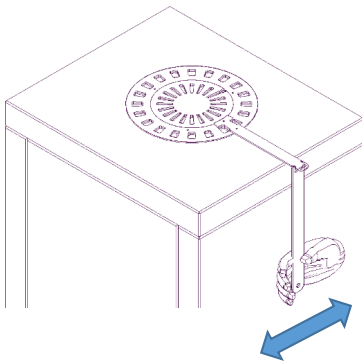
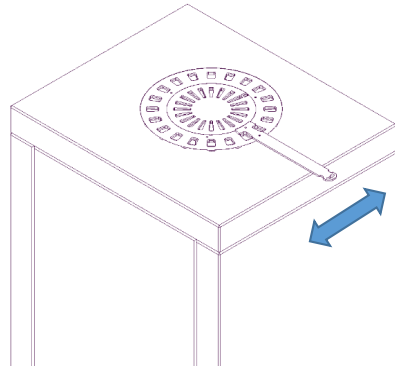
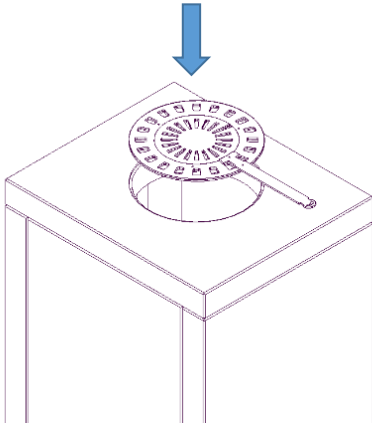

Fig. 9



Top flue - break of the inner ring.

Regulate the convection air flow by turning the handle on the side of the stove.



# SCAN-LINE 50

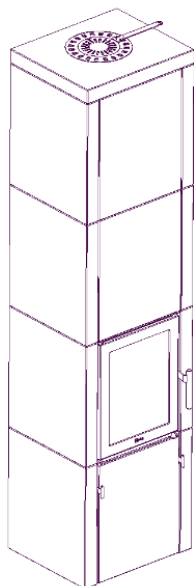

20 standard  
brackets



20 standard  
pins

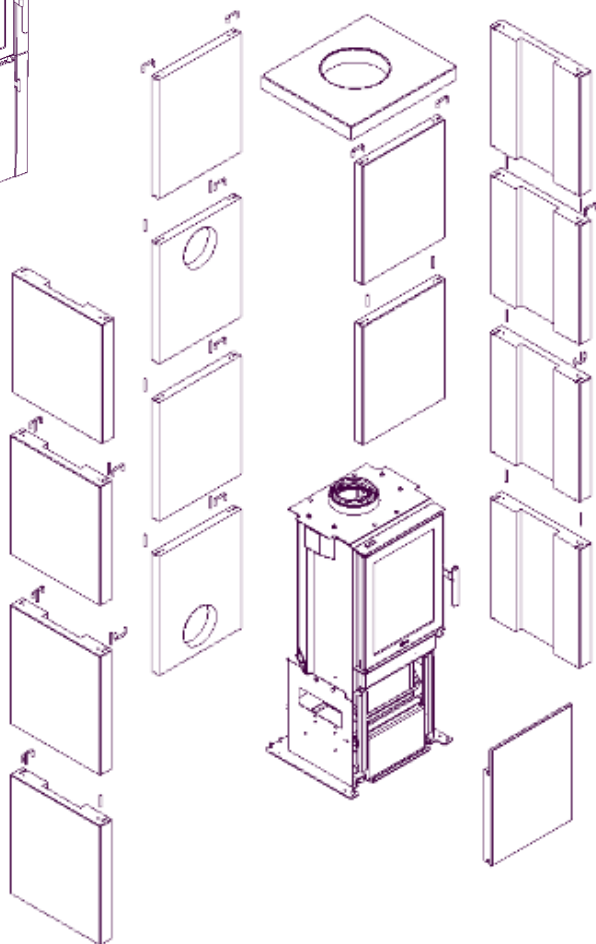

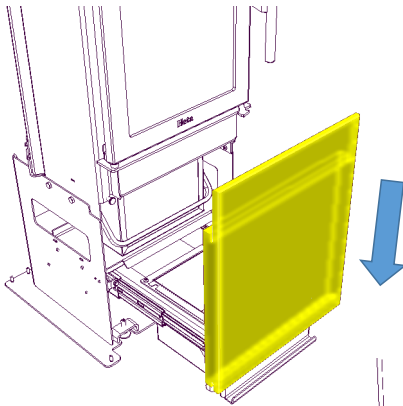

Place the stone into the groove on the door so that it is equidistant to both sides. Important! The stone must be manually held in place until the handle is fitted.

Fig. 2

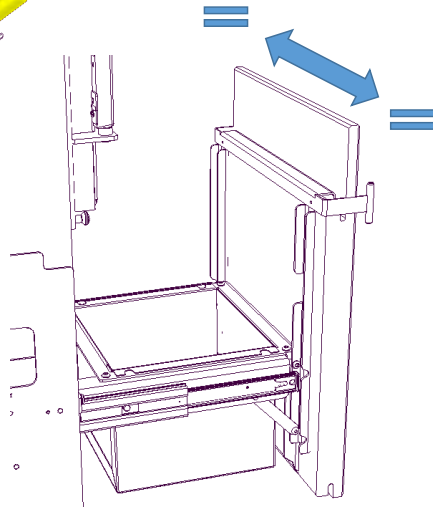

The handle is fitted by placing it into the groove in the stone and the ash pan frame. Adjust the handle so that it is placed in the middle of the ash pan frame.

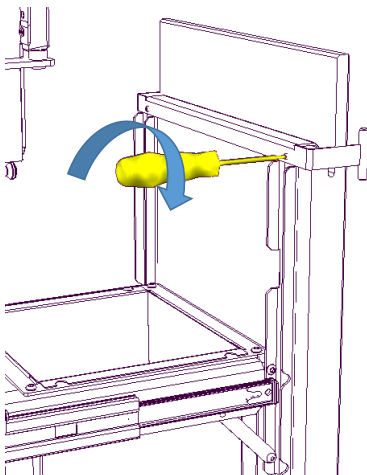

Tighten the handle with the supplied two M5x6 screws.

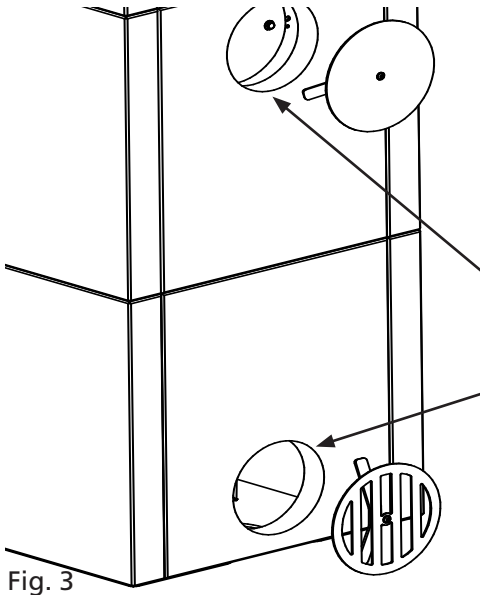

**NB:** Behind the stove, the stone with hole for convection, must be placed at the bottom. The next stone with hole is put on top if there is smoke outlet behind. Fig. 3

The closed cover should be placed here unless the stove should be mounted with back outlet

The open cover should be placed here.

Fig. 3

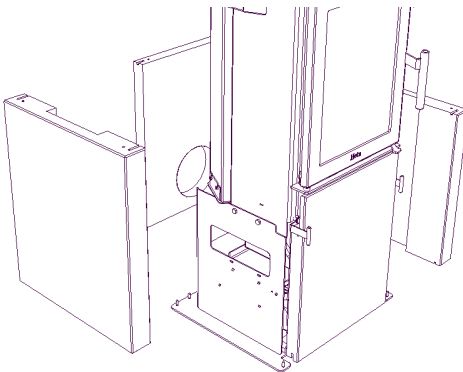

Continue with sidestones as shown i fig. 4. and place Brackets under. Then place the backstone with hole for convection and finish the first round with af sidestone.

Fig. 4

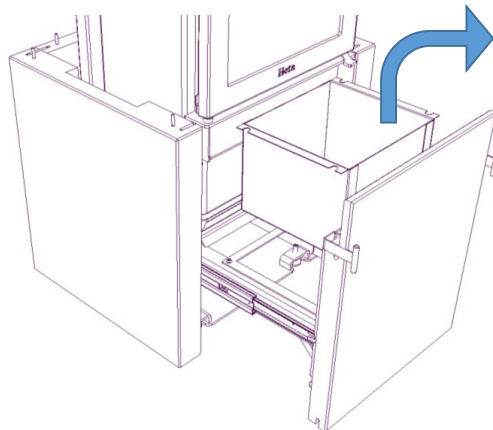
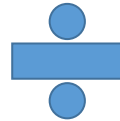
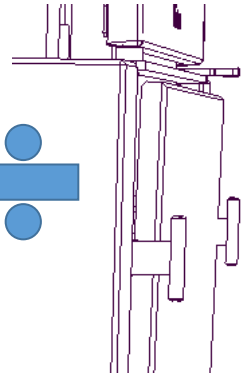
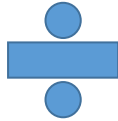
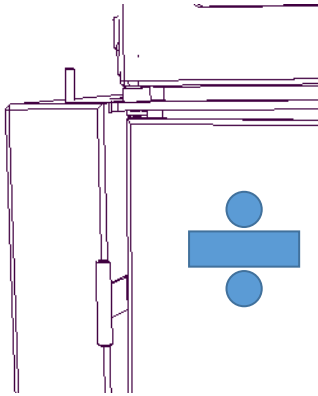
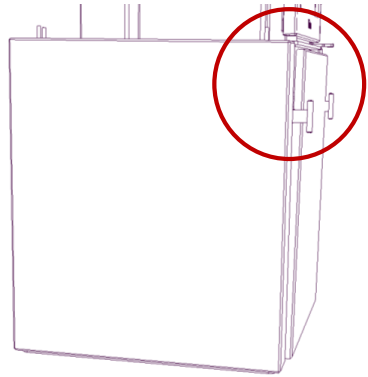
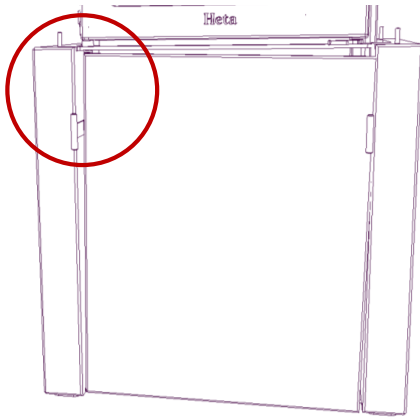

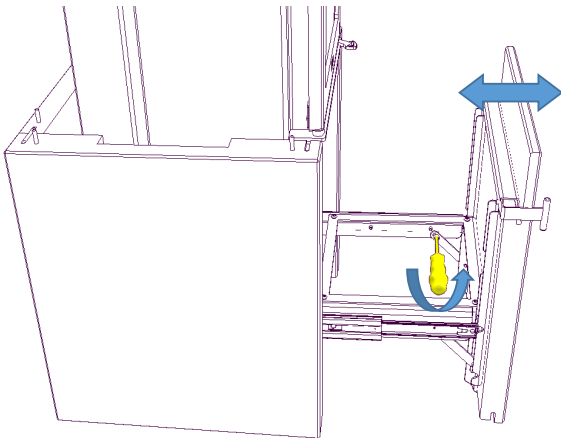
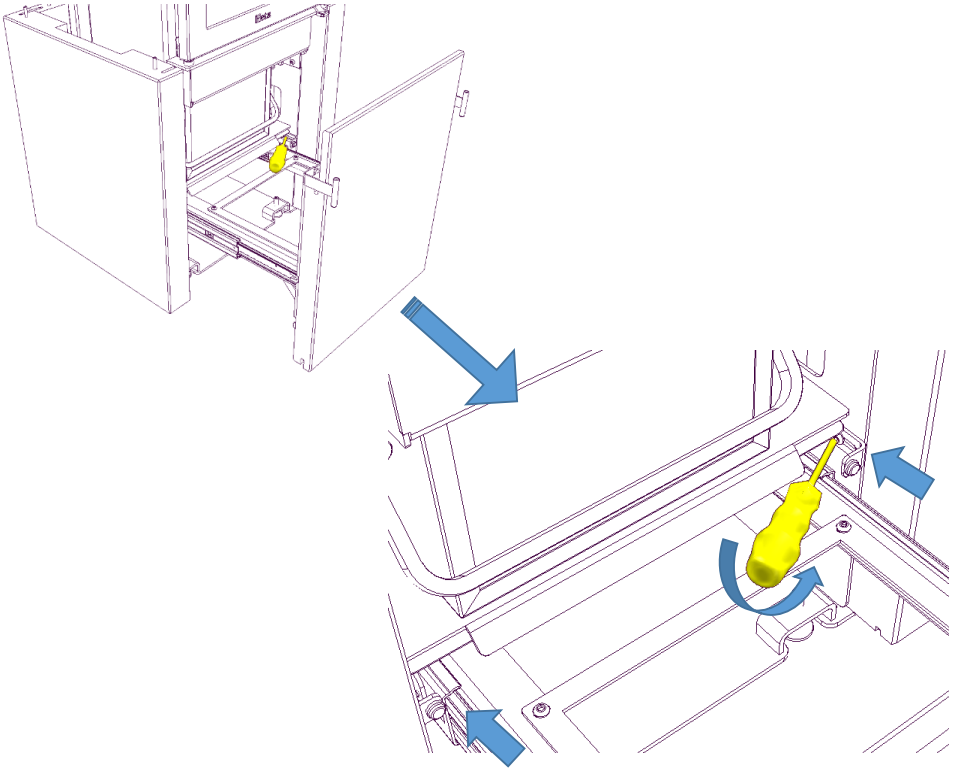



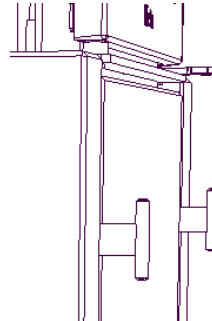
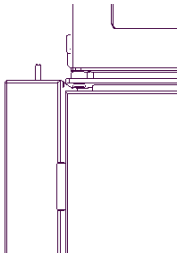
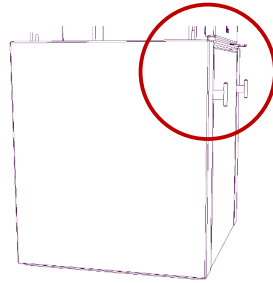
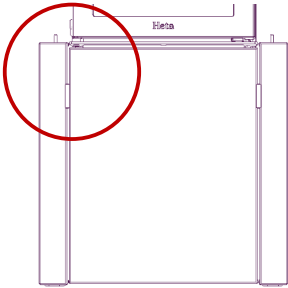
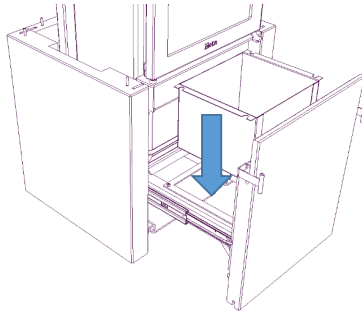
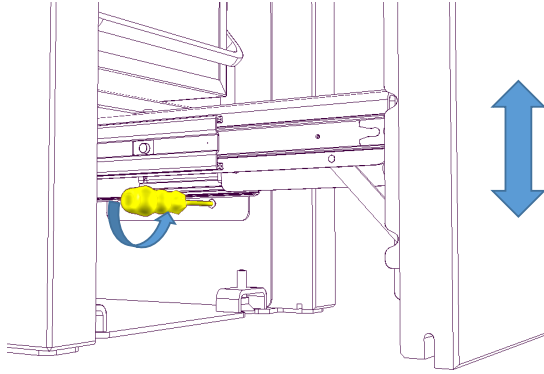
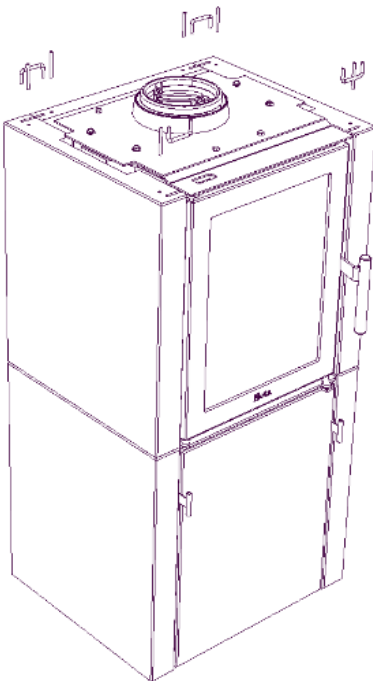
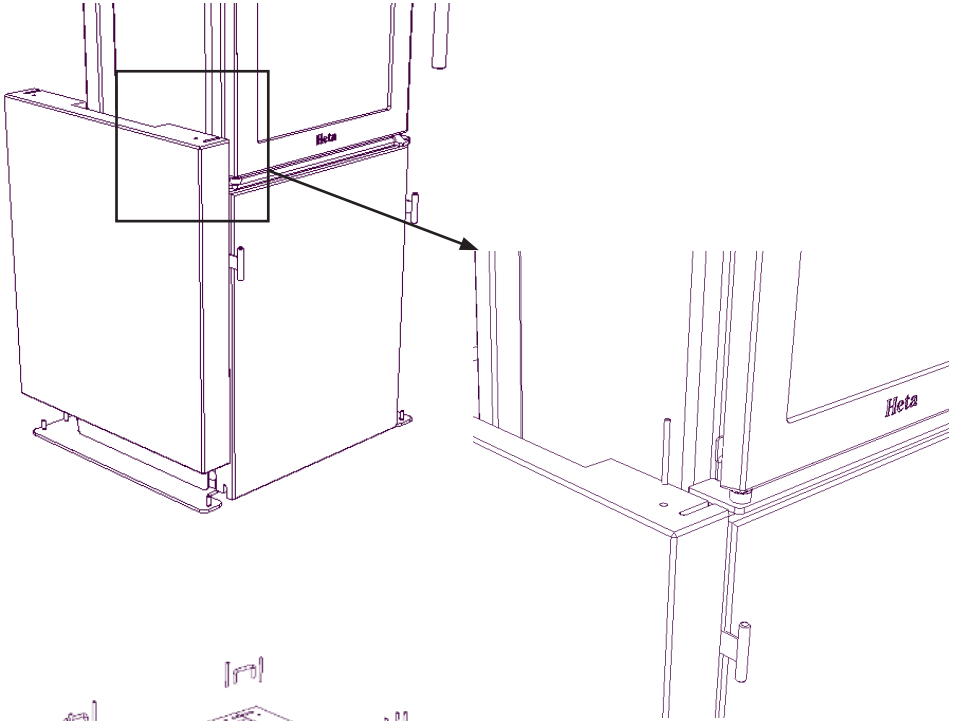

Fig. 5

Put brackets and pins in as shown. fig. 5.



Continuing with the next row. Start with sidestone, backstone and then sidestone again. Place brackets and pins. fig. 6

# THERMASTONES

Optional thermastones are also available. Six thermastones can be installed in this stove.

The thermastones must be added after the soapstones have been placed and the stove/firebox has been adjusted.

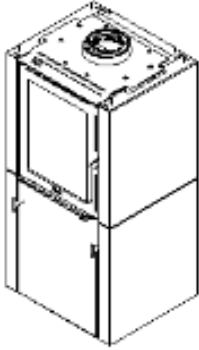

Step 1

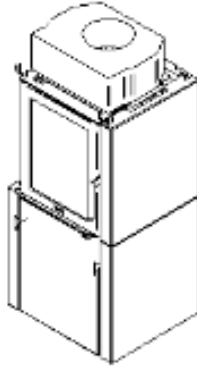

Step 2

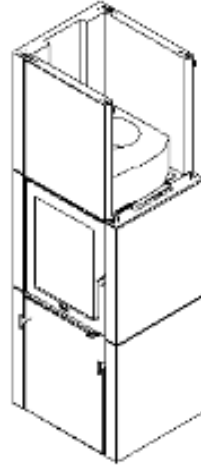

Step 3

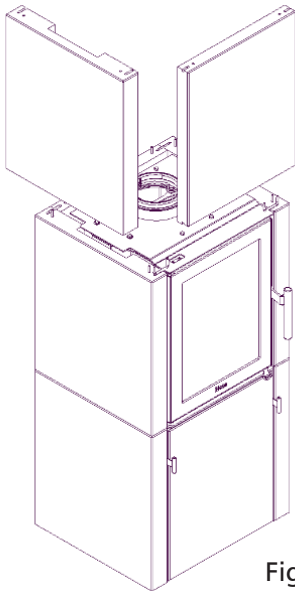

Fig. 7

Continue with the 3. row. Start with the front stone with the two brackets beneath (resting on the metal frame) and then a side stone, which should be placed on the pins/brackets. fig. 7

Continue with the back stone and then another side stone. Place brackets and pins. See fig. 8

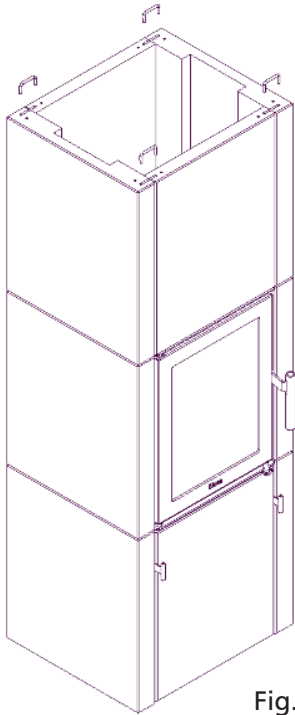

Fig. 8

Place the last row of soapstone. Start with the front stone, then side stone, then back stone and side stone again. Place brackets (no pins are required). See fig. 9.

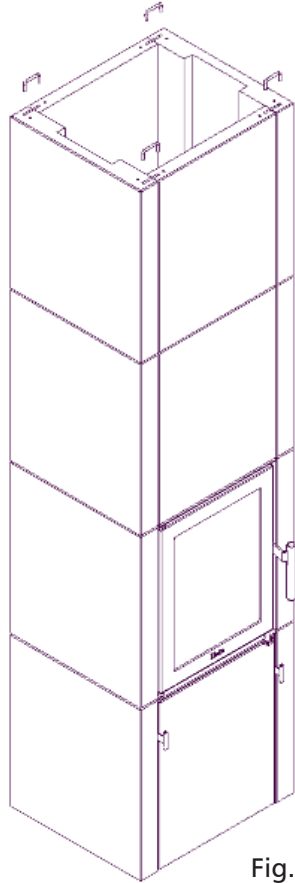

Fig. 9

Finish with the topstone - place it loose on top. If the stove has a top flue, break of the inner ring. Fig. 10

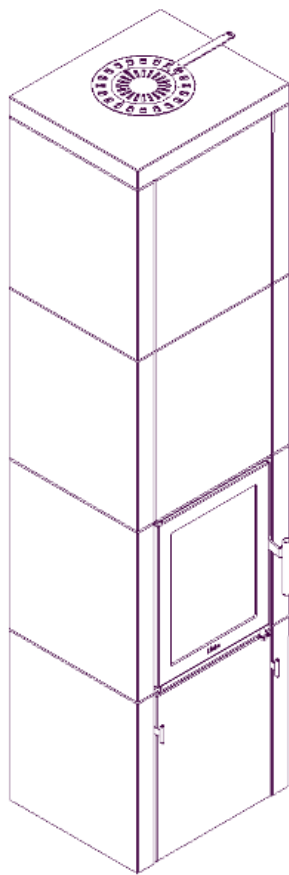
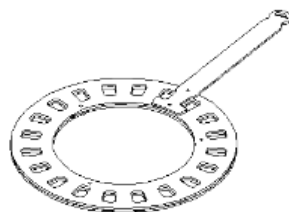
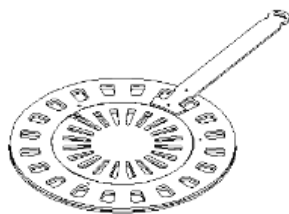

Fig. 10



Top flue - break of the inner ring.

Regulate the convection air flow by turning the handle on the side of the stove.

